

### *EXPLAIN IT WITH ATOMS & MOLECULES*

1. What is the basic difference between covalent and ionic bonding?

2. Write a short caption beside each picture to describe the process of ionic bonding.

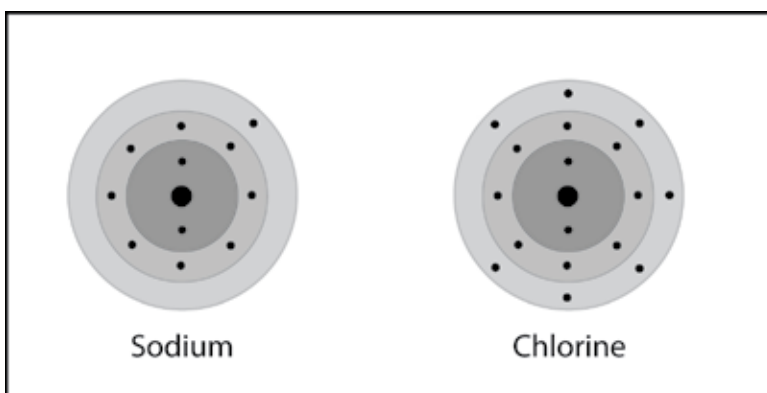

Sodium and chlorine atoms are near each other.

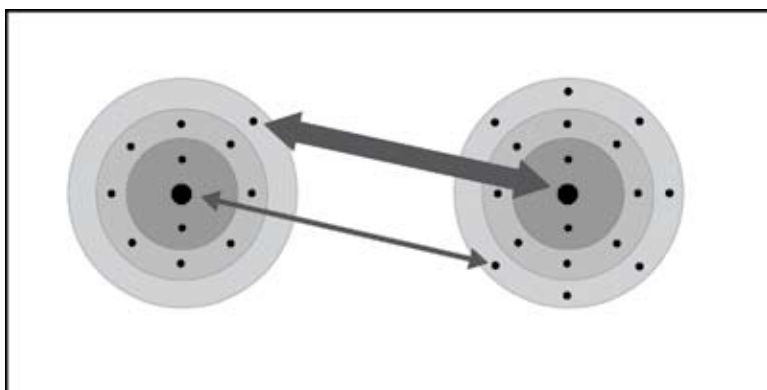

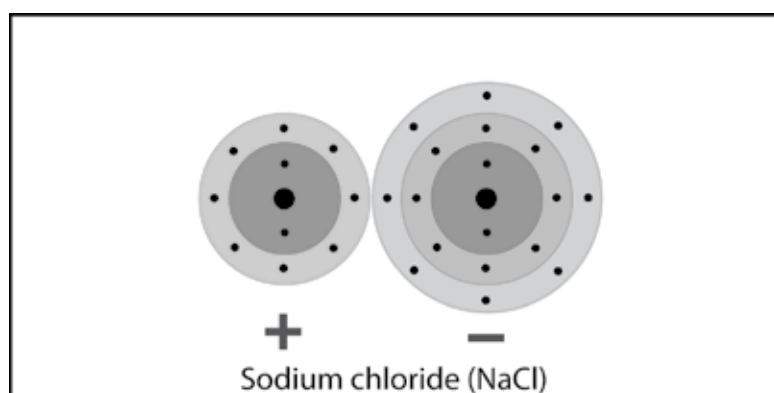
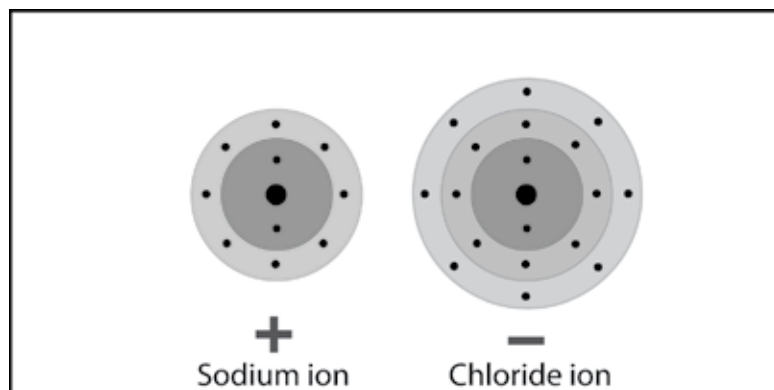
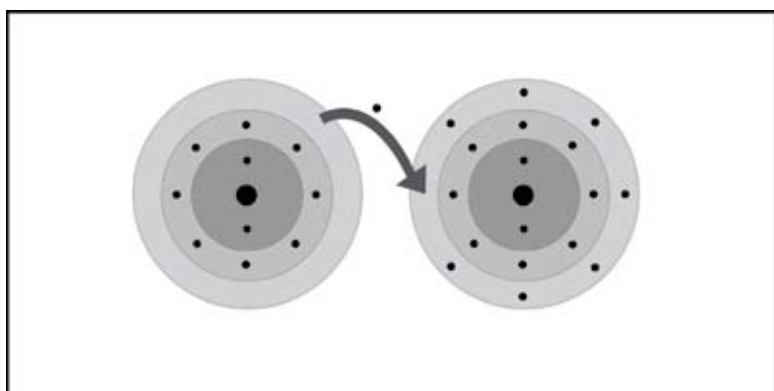

## ACTIVITY



### Question to investigate

Why are salt crystals cube-shaped?

### Materials for each group

- Black paper
- Salt
- Cup with salt from evaporated saltwater
- Magnifier
- Permanent marker

### Materials for each student

- 2 small Styrofoam balls
- 2 large Styrofoam balls
- 2 toothpicks

### Procedure, Part 1

*Observe sodium chloride crystals.*

1. Place a few grains of salt on a piece of black paper. Use your magnifier to look closely at the salt.
2. Use your magnifier to look at the salt crystals in the cup.

### Procedure, Part 2

*Make NaCl units.*

1. Use the marker to put a “-” on the large balls, which represent chloride ions.
2. Use the marker to put a “+” on the small balls, which represent sodium ions.
3. Break two toothpicks in half. Use one of the half-toothpicks to connect the centers of the small and large ions together to make a unit of sodium chloride (NaCl). Do the same thing with the other small and large ball.
4. Use another half-toothpick to connect the two NaCl units in a straight line as shown.



*Put NaCl ions together to make one layer of ions.*

5. Contribute your line of ions to your group and arrange them to make a 4×4 square of ions.
6. Use half-toothpicks to attach the ends of each line to hold the ions together. You only need to place toothpicks in the balls at the end of each line.

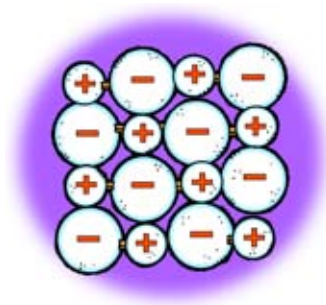

*Build a class sodium chloride crystal.*

7. Give your group's layer of ions to your teacher. Your teacher will stack these to build a model of a sodium chloride crystal.



3. Knowing what you do about sodium and chloride ions, why are salt crystals cube-shaped?

### TAKE IT FURTHER

4. Write a short caption beneath each picture below and on the next page to describe the process of ionic bonding. The first one is done for you below.

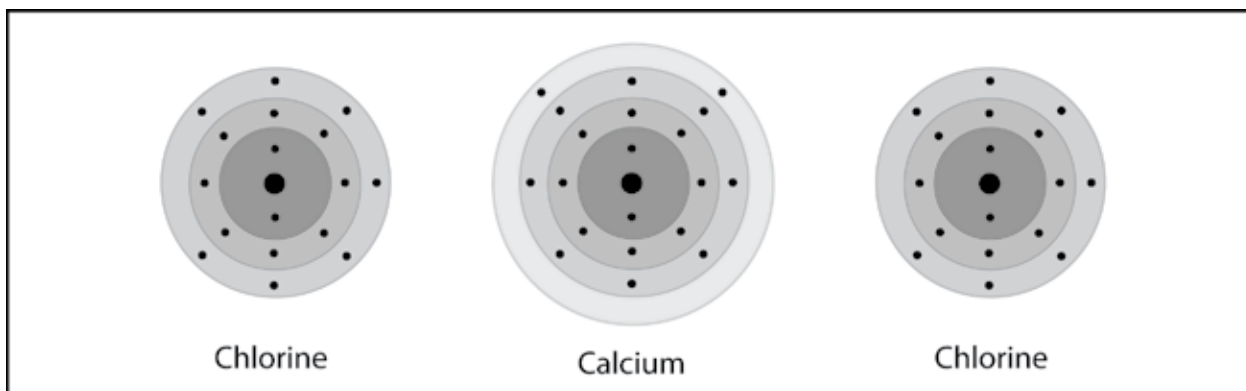

One calcium and two chlorine atoms are near each other.

